

LaserControl NT



reliable tool monitoring

maximum measuring accuracy

precise wear control

BLUM

LaserControl NT

BLUM High-Tech Laser Systems guarantee the highest precision and reliability under the roughest working conditions.

For more than 20 years the LaserControl by BLUM stands for constant manufacturing quality as well as minimized down-times.

The perfect protection, the rugged mechanical design, the high-quality laser and the intelligent electronics guarantee the proven reliability and precision.

Laser Measuring Systems for Machine Tools

- Reduced Set-up Time
- Unmanned Operation
- Reduced Scrap Rate
- Increased Productivity
- High Production Quality

NEW

- Laser Measuring Technology in the 3rd Generation
- Reliable under Extreme Conditions
- Increased Machining Accuracy
- Single Cutting Edge Control at Any Speed
- Programmable by Integrated Microprocessor

Patented



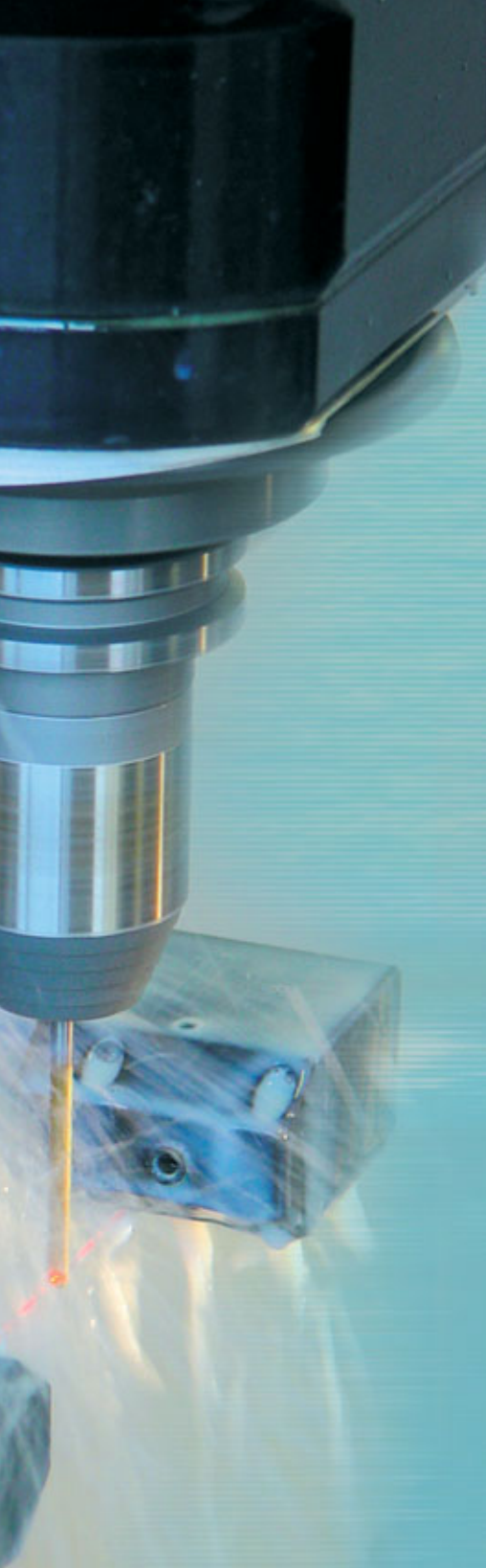

The optic of the BLUM LaserControl NT is perfectly sealed against coolant and chips by a smart mechanical protection system.

The shutter combined with the original BLUM pneumatic unit guarantees low-maintenance operation at minimal energy costs.

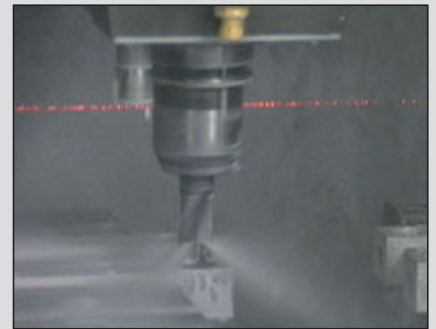

Problem

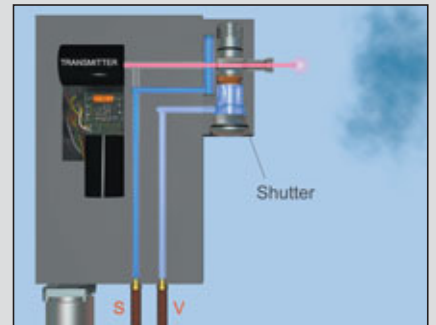

Solution

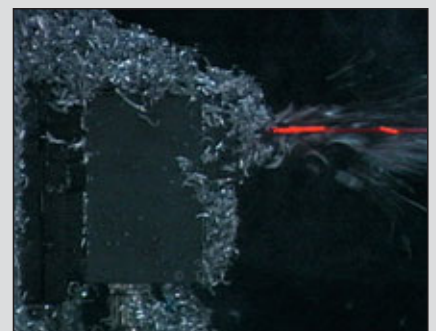

Result

Easy application and 100 % reliability with the BLUM System:

- Laser System
- Pneumatic Unit
- Software
- Service Worldwide
- More than 30,000 installations



BLUM Pneumatic Unit

NEW

LaserControl NT-H

The option LaserControl NT-H is a precision probe which offers the users enhanced features for additional applications. Fixed in XY-direction, all machine axes have thermal compensation. Fixed in Z-direction, this option is used as a calibration head and provides maximum precision for extreme manufacturing challenges.

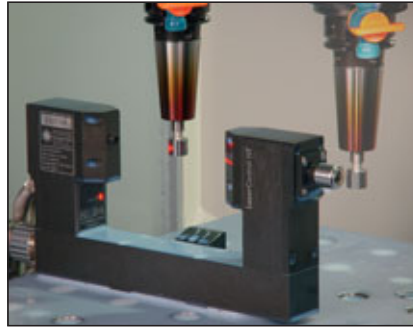

Hybrid Laser for thermal compensation of all machine axes

Your advantage:
Maximum production quality



Hybrid Laser to reach absolute accuracy limits in mold and die applications

Your advantage:
Manufacturing within tightest tolerances

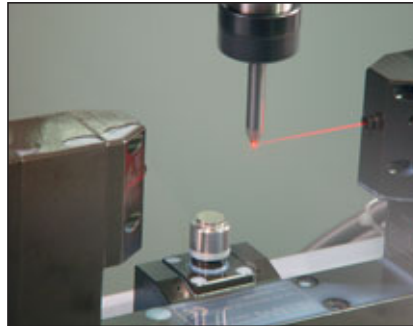

LaserControl EC

High-productive applications often require simple shaft breakage detection only. Modern cutting materials allow only non-contact detection. LaserControl EC for tool breakage detection only serves these requirements in the standard top quality at an attractive price.



Breakage Control

With LaserControl even the smallest tools are checked quickly, safely and guaranteed free of collision. Tough diamond and CBN tools are no problem for the LaserControl.

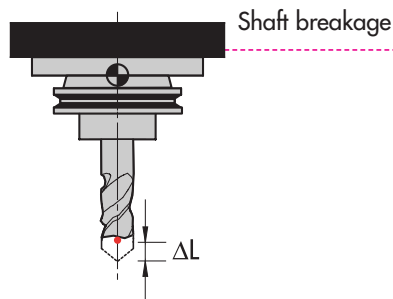

Our proven measuring cycles will guarantee reliable tool breakage monitoring even with a large amount of coolant present.

Your advantages:

- Superior control for unmanned machining operations
- Minimal downtime by in-process error detection and avoidance of consequential damages
- Consistent manufacturing quality by early error detection

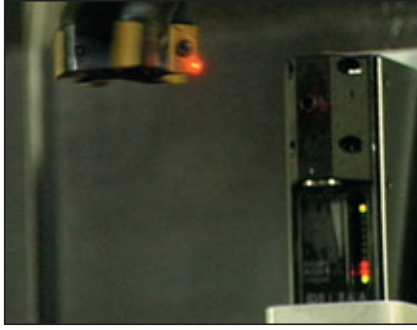

Single cutting edge control

The integrated electronic system checks each individual cutting edge at full speed.

Advantages for your production:

Immediate breakage detection avoids consequential damages.
Flexible solution at economic costs



Tool setting

LaserControl allows fast, precise and automatic tool setting or identification. Length, radius and runout/roundness are measured in the real clamping system at nominal speed. Errors of tool, spindle and tool seating accuracy are instantly measured and corrected.

Your advantages:

- Integrated tool setting with automatic update of tool data
- Constant process monitoring with control of tool data avoid consequential damages due to wear or tool breakage
- Immediate payback by eliminating costly external setting and labor
- Superior part quality due to precise tool length, diameter and radial measuring at nominal speed
- Minimal downtime by quick availability of the tool data
- Quick detection of radial runout
- Minimal risk due to automatic transfer of tool data

LaserControl NT NC Software

BLUM Measuring cycles are available for many NC controls:

Andron, Atek, Brother, Elexa, Fadal, Fanuc, Haas, Heidenhain, Mazak/Fusion, Mitsubishi, NUM, Okuma, Osai, Selca, Siemens, Toshiba, Yasnac

Customized adaptations can be easily developed.

The proven BLUM measuring cycles will cover all your measuring needs.

The measuring programs guarantee the very highest precision, flexibility and in-process quality for your machine tool.

Our measuring cycles are supported by detailed documentation available in many languages.

We will support you at any time with our qualified technical staff.

BLUM measuring cycles will enhance your technology advancement.



Form Control

With optical non-contact measuring, a variety of tools can be measured and scanned fast, precisely and free of collision.

Your advantages:

- On-machine, in-process control of tool geometry
- Consistent manufacturing quality by early detection of cutting edge breakage
- Cost savings due to reduction of defective parts by initiating timely tool change

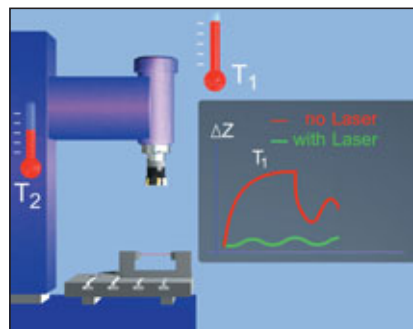
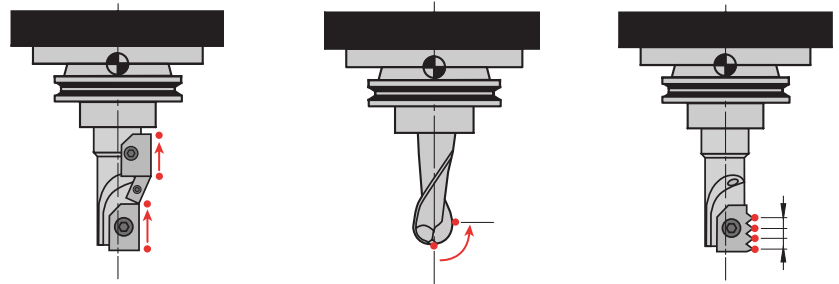

Compensation of the machine axes

The accuracy of today's machine tools is heavily influenced by temperature. The temperature differences within the machine caused by spindle motors, axis motions, the machining process and sunlight cause errors, which can significantly exceed the work piece tolerances.

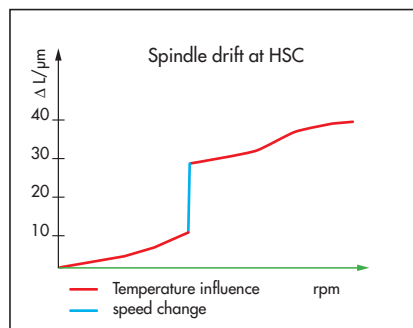

A further problem is the drifting of the spindle at high speeds.

The BLUM calibration tool measures and automatically compensates for temperature drift of machine axis and spindle. The measured drift is corrected by adding a zero-offset.

Your advantage:

With BLUM LaserControl NT, constant high machine accuracy is possible due to automatic correction of drifted axes as well as drifted spindles on high speed machines.

NEW

RunoutControl



With the new software **RunoutControl** the tool is checked within seconds for runout. Tool changing and clamping errors are fast and reliably identified.

Your advantages:

- Reduced rejects
- Increased productivity
- Unmanned operation

NEW – LaserControl for Lathes

ToolTipControl



ToolTipControl enables fast measuring of turning tools and fine boring tools.

Your advantages:

- Reliable wear control on the complete cutting edge geometry
- Reliable breakage control of tough diamond and CBN tools
- Integrated tool setting with automatic update of tool data
- Constant process monitoring with control of tool data avoid consequential damages due to wear or tool breakage
- Minimal risk due to automatic transfer of tool data

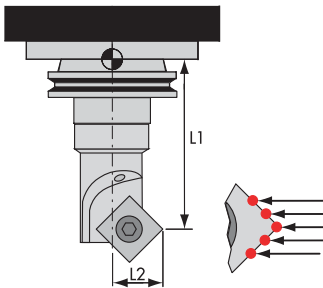

Laser protection class	class 2 acc. to IEC 60825-1 21 CFR 1040.10
Laser type	visible redlight laser/630 – 700 nm/< 1 mW
Protection class	IP68
Current supply	24 V DC / 160 mA
Inputs	24 V DC
Outputs	24 V DC 0-5 V DC analogue output*
Repetition accuracy	Δ transmitter/receiver < 100 mm \pm 0,2 μ m** Δ transmitter/receiver < 1.000 mm \pm 1,0 μ m**
Minimum tool diameter	Δ transmitter/receiver < 100 mm 10 μ m** Δ transmitter/receiver < 1.000 mm 100 μ m**
Test speed (spindle)	750 rpm to 1.500.000 rpm

Technical Data

* Option
** Depending on installation situation, stability of fixation, distance and measuring mode

Option LaserControl NT-H 3rd Axis

Repeatability	0,2 μ m 2 σ
Measuring Force	1,5 N
Minimum tool diameter	> 0,5 mm

LaserControl NT

LaserControl NT mini

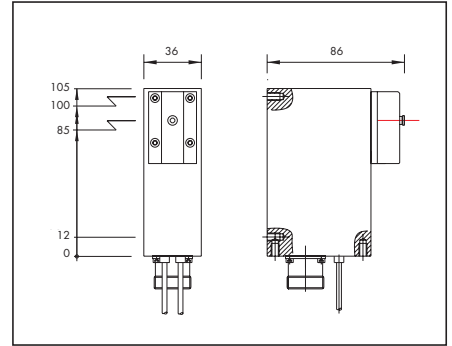

LaserControl micro single

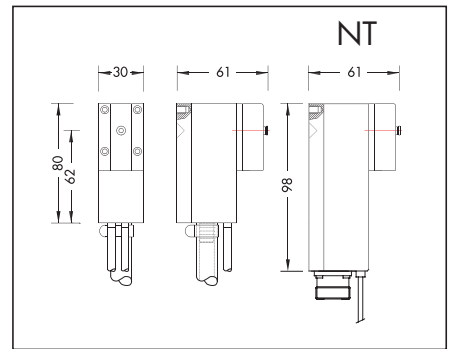

LaserControl NT micro compact

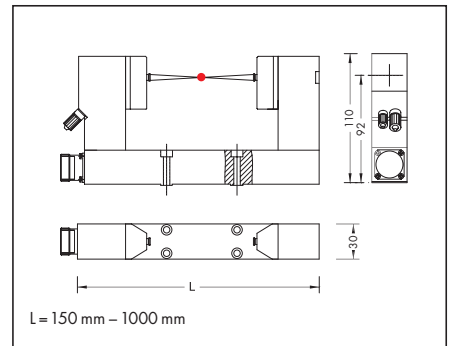
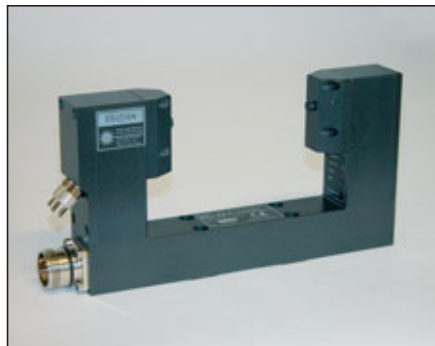

LaserControl NT nano

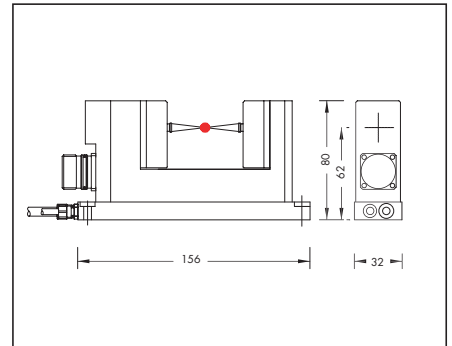
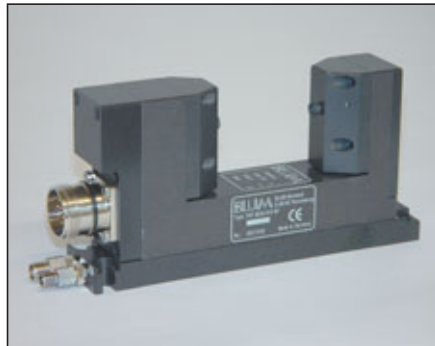

All systems are available in different variants and designs.

BLUM

Production Metrology

Blum-Novotest GmbH
Postfach 1202
88182 Ravensburg
Germany
Tel.: +49 751-6008-0
Fax: +49 751-6008-156
www.blum-novotest.com
E-Mail: vk@blum-novotest.com

Blum LMT Inc.
4144 Olympic Boulevard
Erlanger, KY 41018
USA
Phone: +001 859-344-6789
Fax: +001 859-344-6799
E-Mail: solutions@blumlmt.com

Blum-Novotest Ltd.
33 Townfields
Lichfield
Staffordshire WS13 8AA
Great Britain
Tel.: +44 1543-257111
Fax: +44 1543-251746
E-Mail: info@blum-novotest.co.uk

Blum Laser Measuring Technology Inc.
Cincinnati, USA

Blum Laser Measuring Technology Inc.
Los Angeles, USA

KK Blum Laser Measuring Technology
Nagoya, Japan

Blum Laser Measuring Technology
Taichung, Taiwan

Blum-Novotest GmbH
Representative Office Shanghai, China

Blum-Novotest S.A.R.L.
Bordeaux, France

Blum-Novotest S.R.L.
Como, Italy

Blum-Novotest Ltd.
Birmingham, England